

TUK-A-WAY® SERIES

The GPTWR-25, GPTWR-3, GPTWR-4, GPTWR-5 Series

MAXON®

GPTWR SPECIFICATIONS

The GPTWR series Tuk-A-Way is the #1 selling liftgate series in the world. The newly updated GPTWR now offers a bolt-on extension plate and steps (with and w/o lights). The large aluminum platform makes it ideal for almost every application including large carts or pallets. The Level Ride design keeps the driver and cargo safe and the lightweight aluminum finish will look great for years to come.

- Rust proof extruded all aluminum 60"D X 80"W lightweight platform provides ample size without the higher weight of older steel designs
- Recessed hinge design provides flat loading surface over entire width of platform
- Bolt-on extension plate and steps
- Potted toggle switch
- Power down and power tilt
- The motor solenoid on all GPTWR's has been upgraded from 120 amp to 200 amp for superior performance

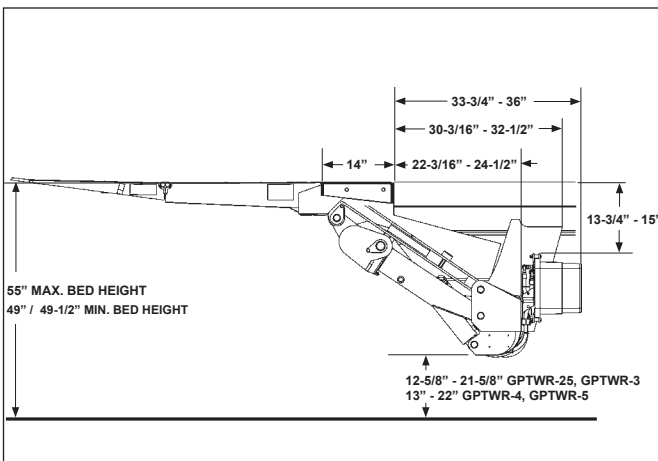

GPTWR Lift Dimensions and Mounting Requirements

Note: Please check Installation Manual for additional walkramp clearance dimensions

MODEL CAPACITY	OVERALL WEIGHT	PLATFORM SIZE	BED HEIGHT
GPTWR-25 (2500 Lbs.)	(1105 LBS.)	60" X 80"	49" Laden
GPTWR-3 (3000 Lbs.)	(1115 LBS.)		55" Unladen
GPTWR-4 (4000 Lbs.)	(1130 LBS.)		49.5" Laden
GPTWR-5 (5000 Lbs.)	(1140 LBS.)		55" Unladen

TUK-A-WAY® SERIES

The GPTWR-25, GPTWR-3, GPTWR-4, GPTWR-5 Series

MAXON®

Standard Equipment

- Bolt-on Extension Plate (note: can also be welded to the body)
- Extruded All Aluminum Platform
- Potted Toggle Switch
- Power Down
- Hydraulic Lock Valve
- Recessed Platform Hinge
- Greasable Pins with Zerk Fittings on All Major Pivot Points

Must Select Options

- Bolt-on Step or Bolt-on Step With Light Cut Outs
- 12" or 6" Long Rubber Dock Bumpers

Optional Features

- 102" Wide Extension Plate
- Street Side Controls
- Cab Cut-off
- Hand-Held Controls
- Circuit Breaker Kit
- Low Voltage Thermal Switch (LVTS)
- Trail Charger
- MaxPro® Paint With Zinc Enriched Primer
- Max On-Lock (Dock Lock Receiver- by Special Order Request)
- Cart Stops (Single or Dual)

Distributed by:



Bolt-On Extension Plate and Steps

Bolting on the extension plate and steps, versus the current practice of welding, has two crucial advantages: it overcomes corrosion issues - induced by welding and repainting and it simplifies installation.



Aluminum Platform

Lightweight aluminum platform design with recessed hinges provides a flat loading surface over entire width of platform. The platform features dual assist torsion springs that minimize the opening and closing force.

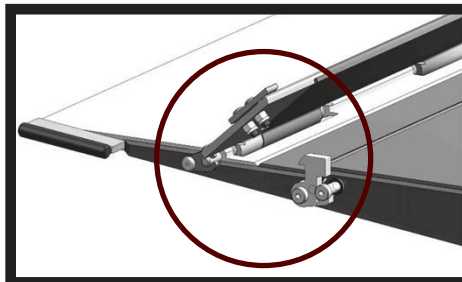

Cart Stops

Cart stops are an available option in both single and dual versions. The new design features a simple locking pedal that allows the operator to activate the use of the cart stop(s) at his discretion.

Note: Available platform load area will be reduced by 9 1/2" when utilizing the cart stops.



Max On-Lock

By special order request (SOR) all GPTs can be ordered with the Max On-Lock kit which makes them compatible with the most common vehicle dock restraint systems.



MaxPro® Paint Process

All Maxon liftgate products come standard with MaxPro® paint. MaxPro® is a state-of-the-art painting process that consists of stellar pre-treatment, one of two primer options (aluminum **standard**/zinc-rich **optional**) and an exclusive patented polyurea top coat.